

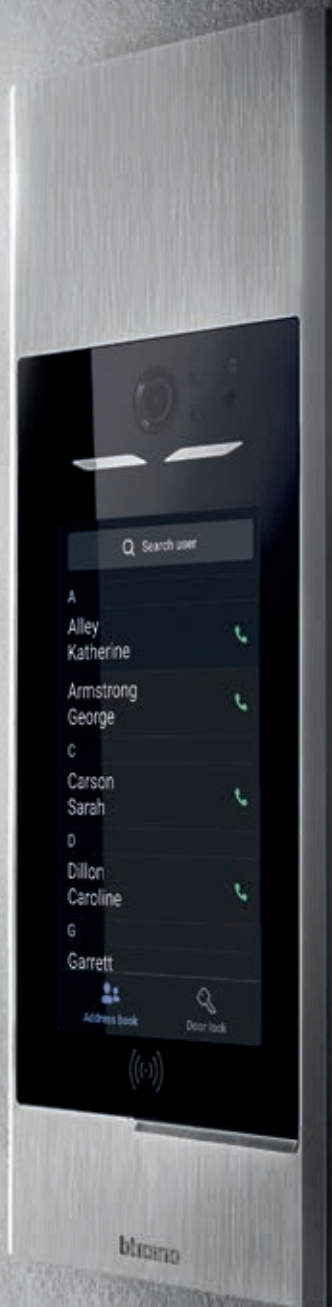

DIGITAL.  
FUNCTIONAL.  
PERFORMING.

# LINEA 5000

WITH  
Netatmo



#ImprovingLives



**bticino**

A brand of  legrand®



Linea 5000 provides a complete building access experience, from installation to daily use and maintenance, perfectly adapting to the modern lifestyle.

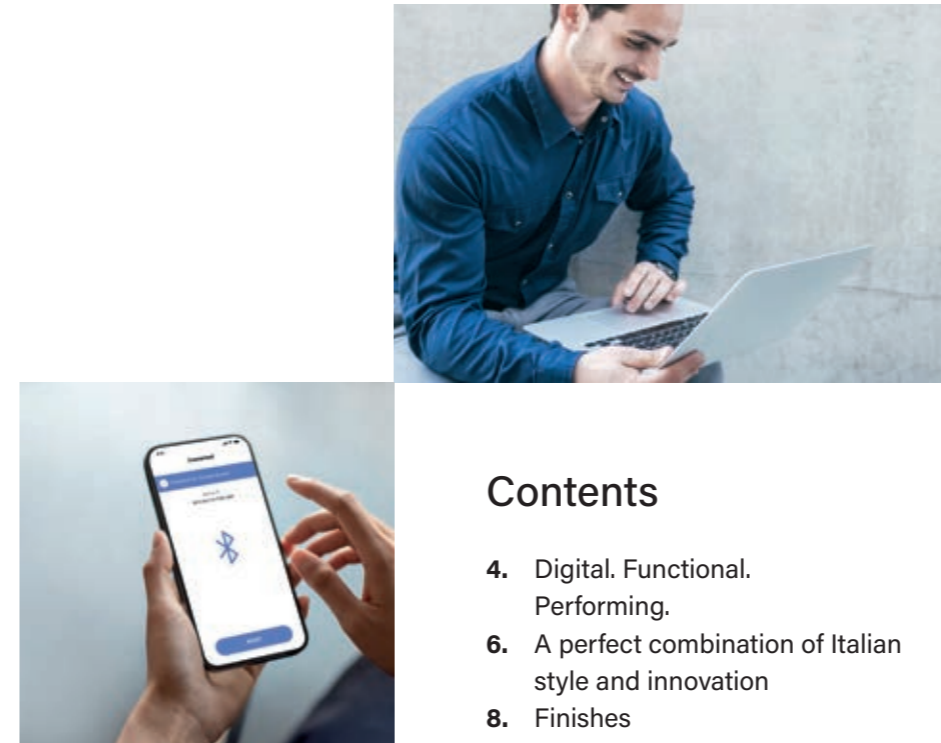

## Contents

- 4. Digital. Functional. Performing.
- 6. A perfect combination of Italian style and innovation
- 8. Finishes
- 10. BTicino 2 Wires technology
- 12. Smart configuration with Home + Project
- 16. Physical and digital customisation
- 18. Call modes
- 19. Access modes

## Technical features

- 20. Connections and functions
- 21. Main features
- 22. Additional modules
- 24. Installation contexts
- 26. Installation modes

## Catalogue and dimensional data

- 29 - 33 Catalogue
- 34 - 37 Dimensional data
- 39. Online Tools

# Linea 5000

## Digital. Functional. Performing.

**Linea 5000 with Netatmo is the new BTicino 2 Wires Smart entrance panel.**

Ideal for the "digitalisation" of multi-family settings, it takes access to modern buildings to the next level. Featuring a large 7" touch screen display, a wide angle HD camera, digital filters and a modern and intuitive graphic interface, it integrates perfectly with contemporary buildings, conveying a feeling of innovation and high quality.



- 2 WIRES**
- IP65**
- IK08**
- 7"**
- HD**
- 

**Access the building in different ways:**

- \*\*\*  
\*\*\*  
\*\*\***  
CODE
- KEY CARD
- SMARTPHONE

In summary, Linea 5000 with Netatmo is a modern, safe and customisable digital experience, ideal for building access control and suitable for any installation situation.



# Linea 5000

A perfect combination  
of Italian style  
and innovation



Inspired by modern architecture, Linea 5000 offers cutting-edge design, sophisticated details and innovative functions, enhancing the value of any entrance. The aluminium frame protects the display, while the bevelled edges give it a slim and yet sturdy appearance.

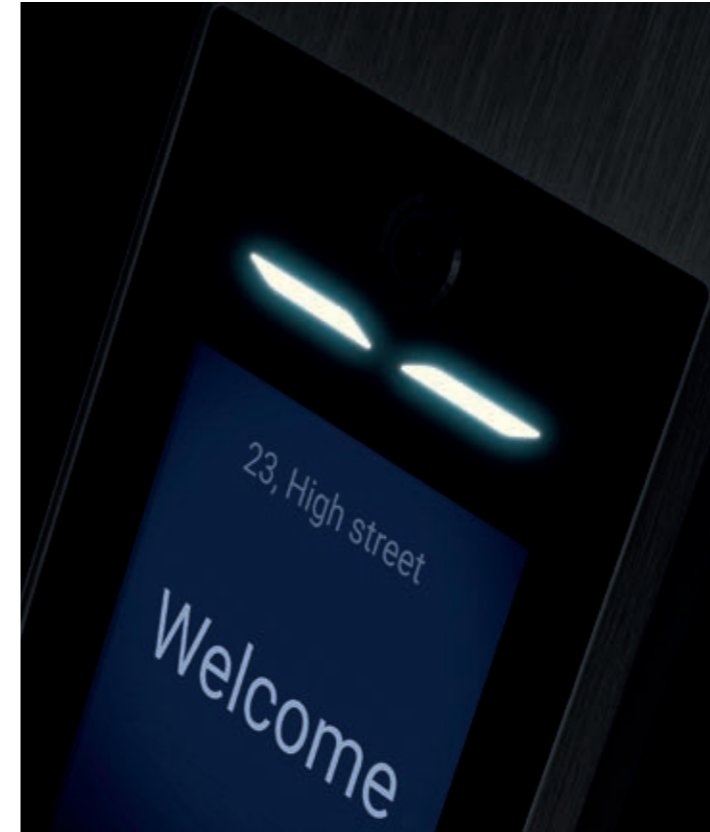

The technology, including the sensors, is hidden behind dark glass that activates automatically when approached.

Sophisticated details  
and durable materials exude  
style and high quality.



# Linea 5000

5 exclusive finishes to add value to every entrance.

**Find the solution for any room.**

With 5 exclusive finishes in 60% recycled aluminium Linea 5000 with Netatmo can be easily adapted to all types of buildings, from contemporary of any size to classic architecture. Linea 5000 expresses robustness and high quality in every colour.

Two finishes in the catalogue.



Three finishes on demand made to order or project.

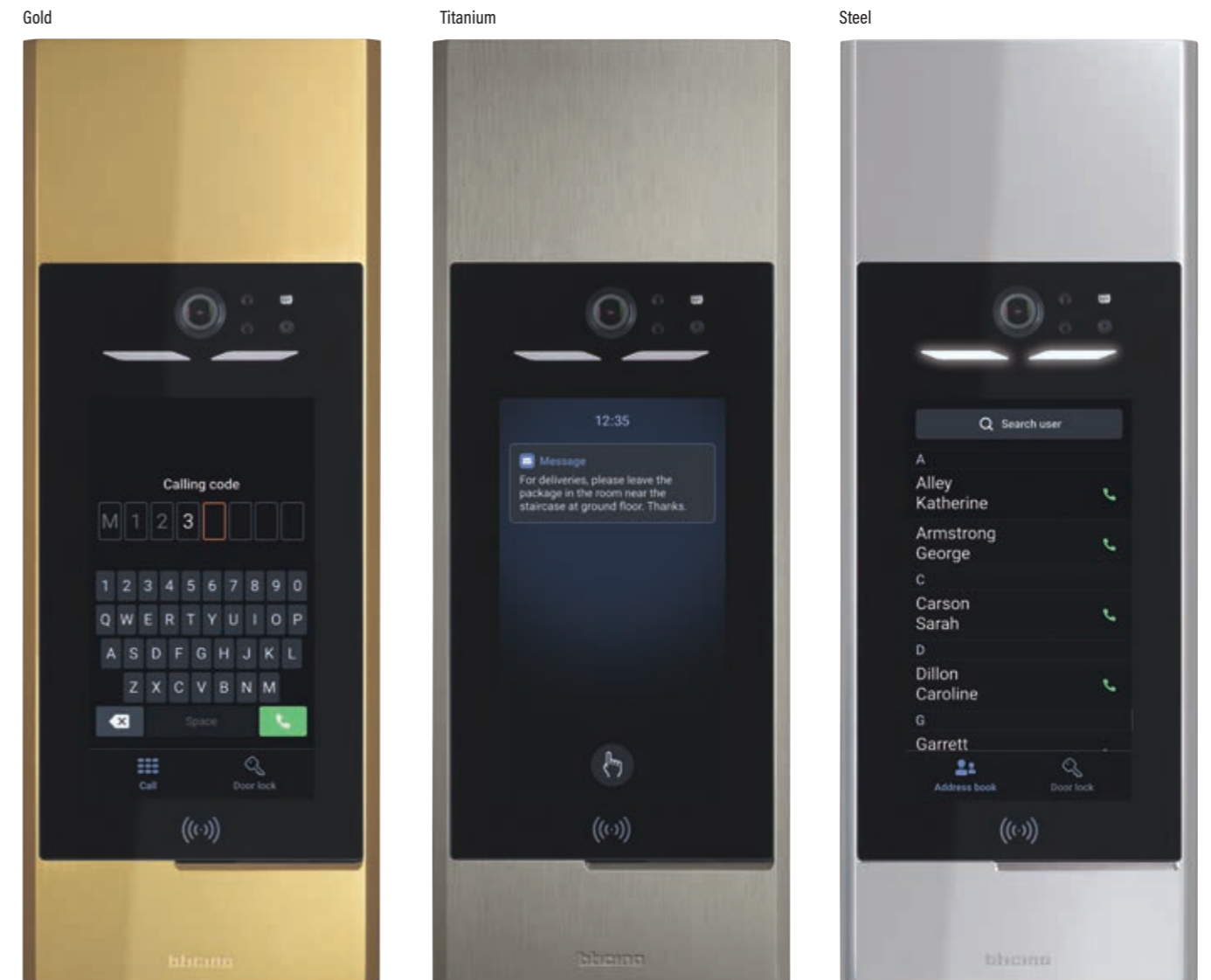

# Linea 5000

BTicino 2 Wires technology.

No changes to your working habits. Same installation rules as for the 2 wires entrance panels.



Ideal for upgrading existing 2 wires video door entry systems (e.g. systems with Sfera entrance panels or traditional brass pushbutton panels). **Bring your old system to the digital era with the new Linea 5000 with Netatmo.** Perfectly compatible with all the devices of the BTicino 2 wires video door entry system range: Classe 100 and Classe 300EOS video internal units, power supply units and system accessories.

## Linea 5000 is suitable for all home environments.

With 2 wires technology and the possibility of customising the finish with the desired colour, logo and street number, it guarantees maximum adaptability in any living context.

Building



Apartment block



Villa



## A sustainable approach



### Wide angle HD camera

**Resolution:** 5 Megapixels  
**Digital filters**  
**Horizontal field of view:** (130°)  
**Viewing field angle (diagonal):** 160°

NOTE: The HD digital video signal is transmitted to internal units via PAL encoding on 2 Wires BUS SCS technology.

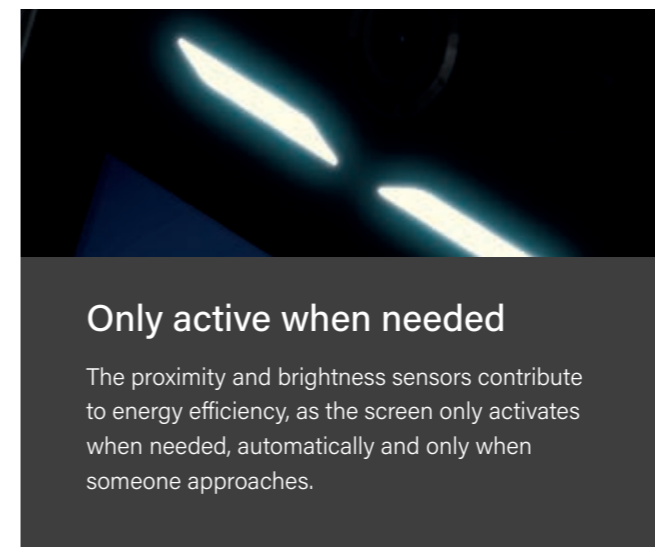

### Only active when needed

The proximity and brightness sensors contribute to energy efficiency, as the screen only activates when needed, automatically and only when someone approaches.

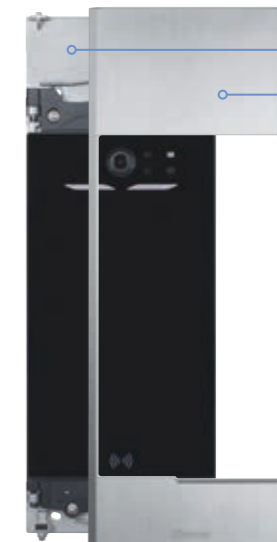

**Recycled aluminium**  
 The fixing frames of the Linea 5000 modules and the finishing frames are made of **60% recycled aluminium.**

# Linea 5000

## Smart Configuration with Home + Project

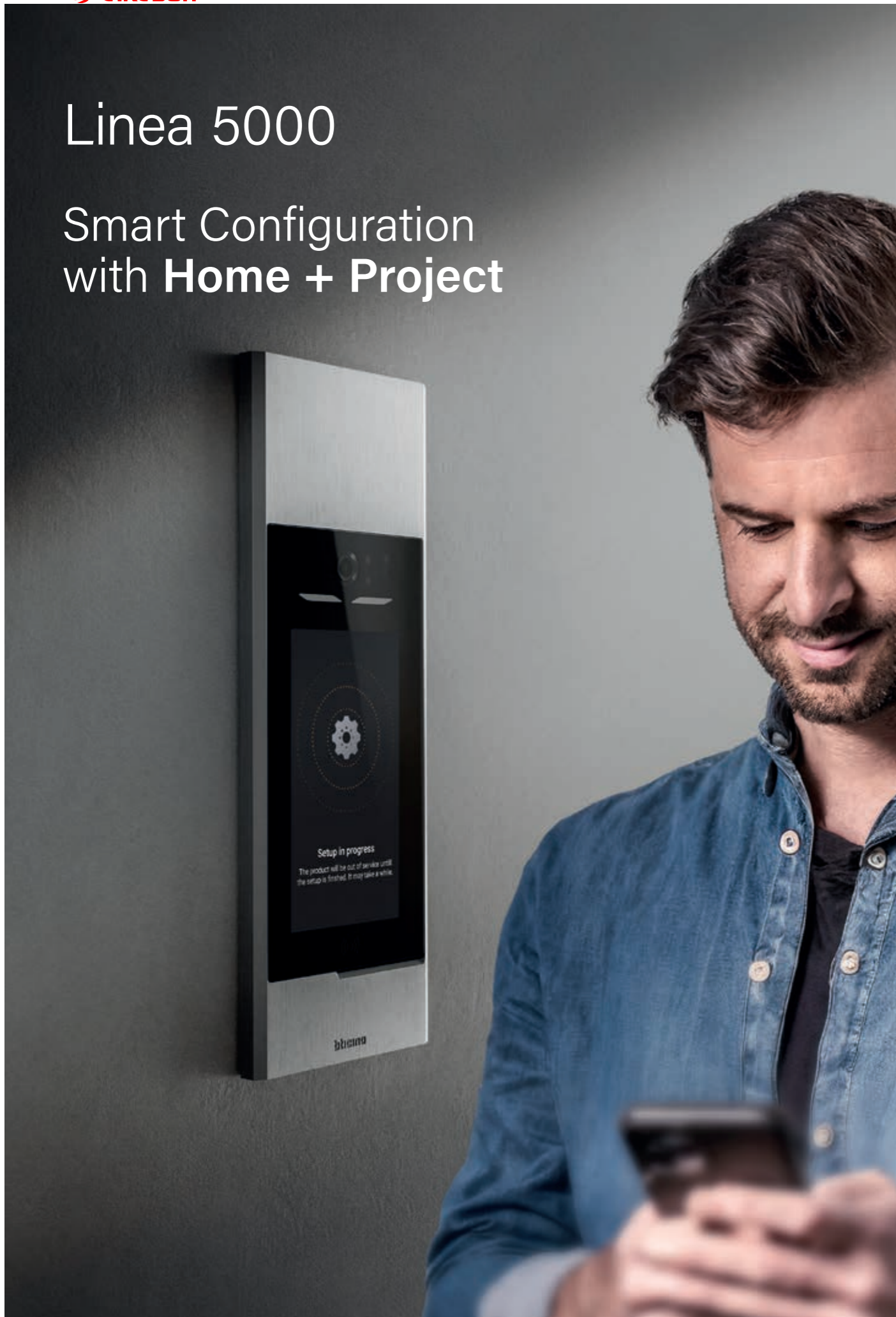

### A new experience. Completely digital.

Linea 5000 with Netatmo will allow you to make your work "digital", and therefore more efficient, for a whole new user experience. Thanks to the Home + Project app, it will also be possible to remotely digitally configure, manage and update the pushbutton panel using a smartphone or PC, quickly and without the use of physical configurators.

With the new Linea 5000 with Netatmo, working has never been so smart.

HOME + PROJECT IS COMPLETELY FREE AND CAN BE DOWNLOADED FROM THE APP STORE AND GOOGLE PLAY



HOME + PROJECT

# Linea 5000

Configure your system with full ease.



## SMART APTITUDE.

The very useful Copy&Paste function avoids the need of having to create every time a new system from scratch: simply copy a similar projects and make any necessary changes to achieve full customisation. Time savings are guaranteed, especially when designing multi-apartment systems or systems for blocks of terraced houses.



## HOME + PROJECT. To digitally design, configure and customise the video door entry system

HOME + PROJECT - a new work tool for the installer. Available as a web app for Desktop PCs at <https://homeproject.legrand.com> and as a smart device mobile app for on-site configuration. The App automatically recognises the devices in the system to be configured, can replicate in other homes the stored projects and allows to maintain the system remotely.

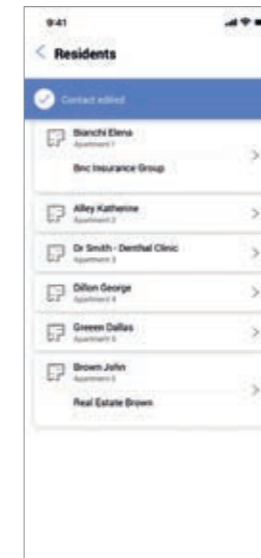
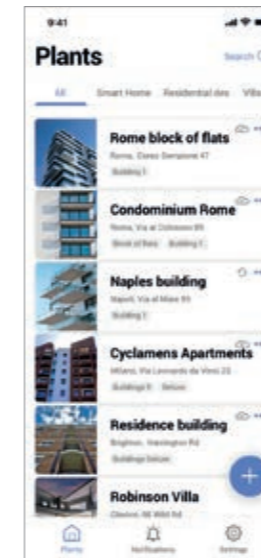

## REMOTE ADDRESS BOOK EDITING

This digital tool helps simplify not only the configuration process, but also maintenance and customisation. Modify system parameters, update the address book and download the new entrance panel configuration, either remotely or directly on site via Bluetooth connection.



# Linea 5000

## Total adaptability.

The extensive customisation options, both physical and digital, bring unique freedom of expression. Possibility of customised finishes, with frames in assorted, logo and street number for total adaptability. All this makes Linea 5000 with Netatmo particularly suitable for **meeting the customisation requests from architects, design studios, real estate developers and customers.**



### Physical customisation of the finishing frames

Using the specific online tool, it is possible to customise the finishing frames. Frames for customisation must be ordered using the specific custom part numbers (V/345101-02-03-04-05) - see the relevant catalogue pages.



### Digital customisation of the display

It is also possible to customise the display screens by changing the names of the residents in the address book, the display mode, adding a logo / address, as well as displaying messages for visitors/couriers, etc.

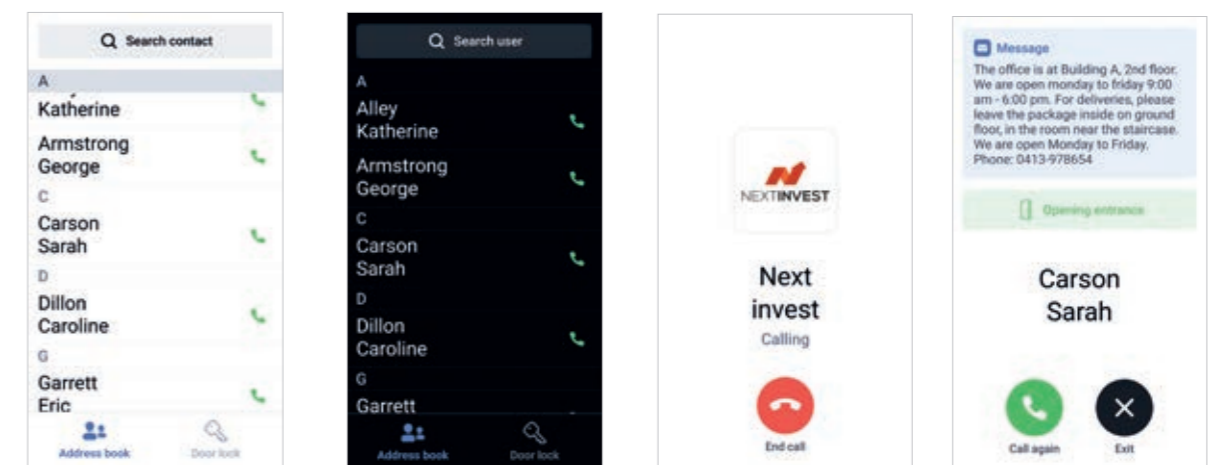

White mode: for clear and intuitive use.

Dark mode: protect your eyes and save battery life.

The logo of adds a very personal touch.

Customisable messages for Airbnb guests, couriers and visitors.

# Linea 5000

Multiple call modes.  
Smart call.



### ADDRESS BOOK

with list of residents' names.

### CALL WITH CODE (numeric or alphanumeric)

In this mode, in addition to the code you can also choose to have the address book.

### APARTMENT BLOCK/RISER/FLOOR/ APARTMENT

Entering the exact address of the apartment to call in the system.

Multiple access modes.  
Smart access.

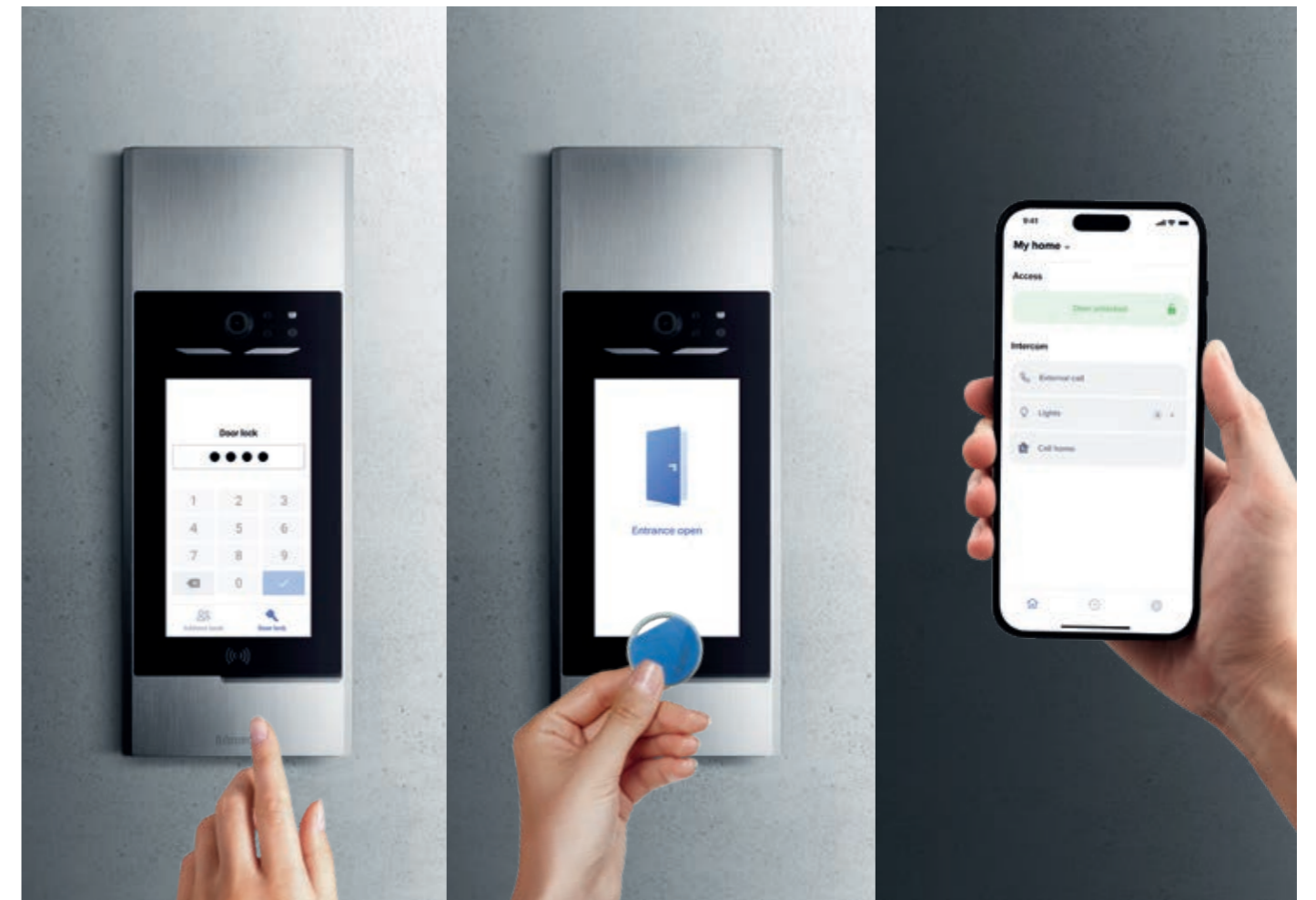

### NUMERIC CODE

Pre-set.  
(maximum of 5 access codes, also with date/time schedule).

### RFID KEYCARD

Pre-programmed / registered.  
Keycards available in different colours.



### SMARTPHONE

With Home + Security App  
via Bluetooth connection.



Front view

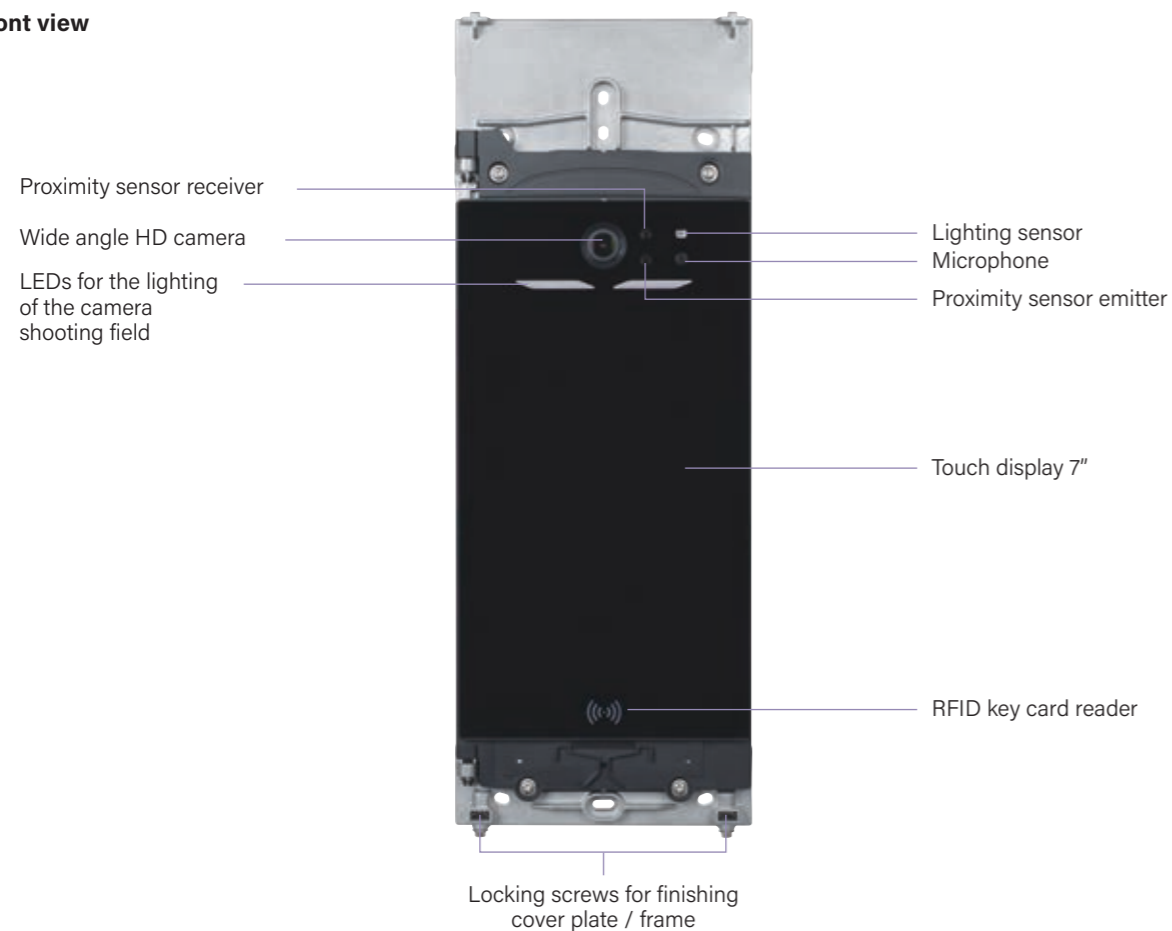

Rear view

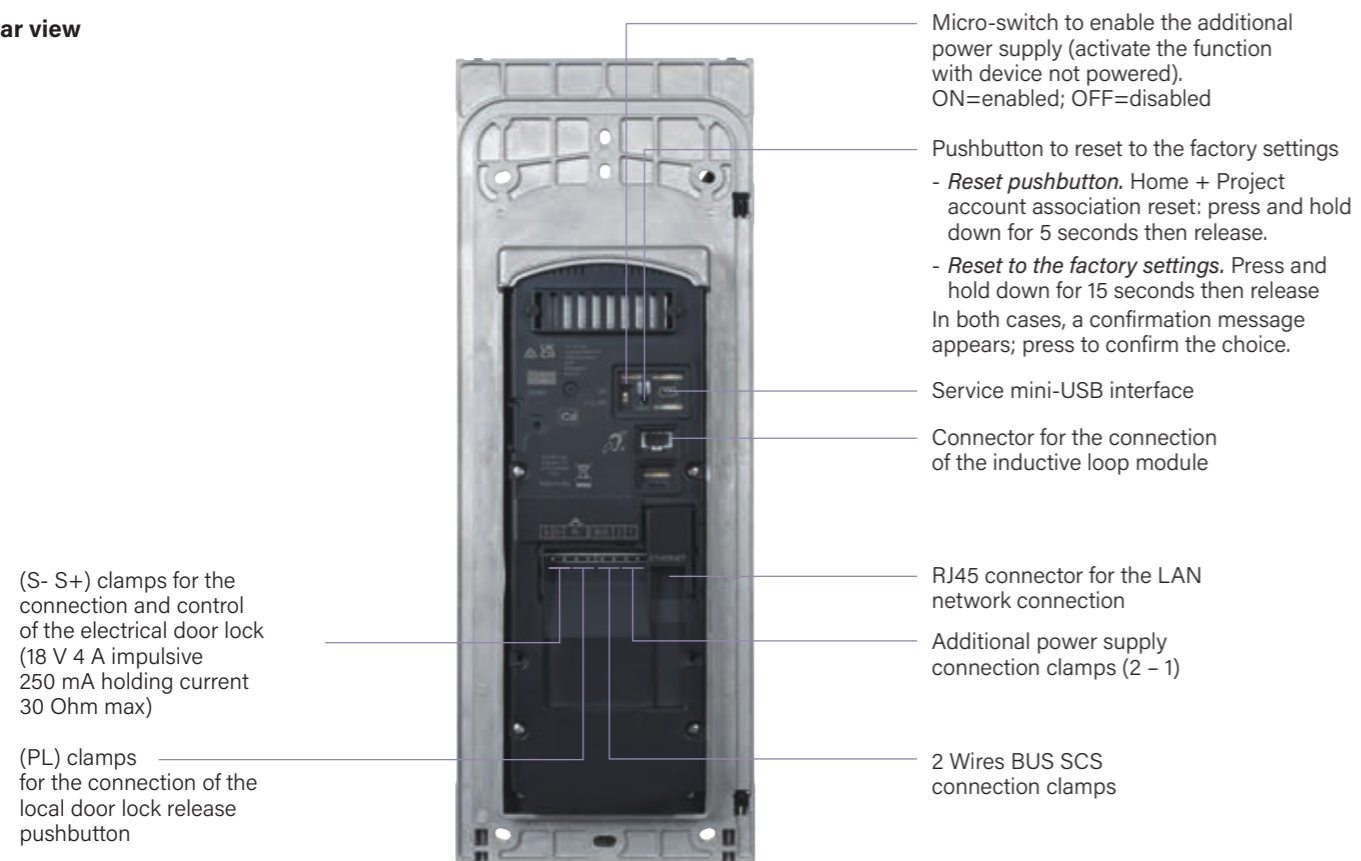

Display module

- BTicino 2 Wires BUS SCS technology;
- Wide angle HD camera - 5 Megapixels;
- Touch screen vertical display 7";
- Built-in RFID keycard reader ;
- IP65 protection index;
- IK08 protection index against mechanical impact;
- Flush mounted installation;
- Wall and surface mounted installation;
- Twilight sensor and night vision;
- Digital microphone with echo eliminator;
- Voice feedbacks;
- Theme change – display mode (light/dark);
- Local configuration via Bluetooth;
- Remote configuration via Ethernet / Wifi;
- Update of the residents' address book using the app (H+P and H+S);
- Direct call to the guard station (if present);
- Compatible with the additional Inductive Loop module.
- Compatible with the additional keypad module.



Inductive loop module



Keypad module



RFID Smart Access module

The Linea 5000 with Netatmo offer also includes 3 additional accessory modules, which can be installed in systems with at least 1 Linea 5000 display module, item 345000.

**Keypad accessory module**

It allows the activation of an electrical door lock by means of a code. It is fitted with relay contacts (C – NO - NC) and clamps for the connection of a local door release pushbutton and can be programmed using the Home + Project app. It has the visual notification of the access status and night backlighting. To be completed with an appropriate frame, it can be used stand-alone or combined with a display module. Can be installed in 1-module flush mounted box, in wall mounted box or with dedicated accessory for 3+1 composition.



Aluminium finish



Nickel finish

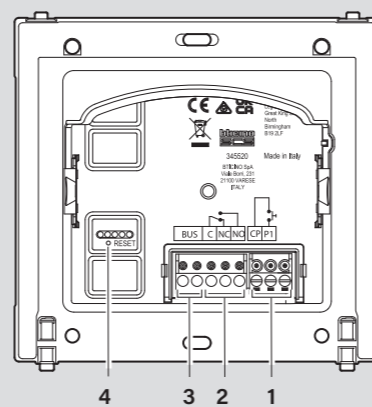

- 1 – Connection of the local door lock release pushbutton;
- 2 – Built-in relay contacts;
- 3 – 2 wires SCS/BUS connection;
- 4 – Pushbutton to reset to the factory settings.



**RFID smart access accessory module**

It allows the activation of an electrical door lock by means of a keycard or with Home + Security app via bluetooth. It is fitted with relay contacts (C – NO - NC) and clamps for the connection of a local door release pushbutton and can be programmed using the Home + Project app. It has some LEDs for the visual notification of the access status and night backlighting. To be completed with an appropriate finishing frame, it can be installed in 1-module flush mounted box or in wall mounted box for surface installation.

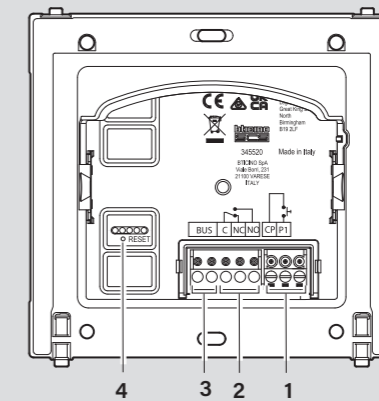

- 1 – Connection of the local door lock release pushbutton;
- 2 – Built-in relay contacts;
- 3 – 2 wires SCS/BUS connection;
- 4 – Pushbutton to reset to the factory settings.

**Inductive loop accessory module**

It allows people wearing hearing aids fitted with (T) selector to use audio door entry communication. It is connected to the display module using the multicable supplied. To be completed with the appropriate finishing frame. Installation in 1-module flush mounted box or with the dedicated accessory for 3+1 composition.

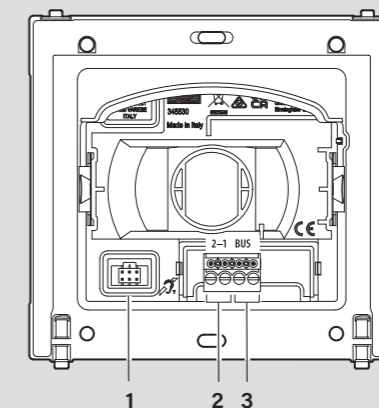

- 1 – Connection to the display module 345000;
- 2 – Local power supply (2 – 1) connection;
- 3 – 2 wires SCS/BUS connection.

Designed for multi-family apartment blocks



Ideal for the "digitisation" of multi-family settings, Linea 5000 takes access to modern buildings to the next level. The 2 wires technology makes it possible to install all types of systems.

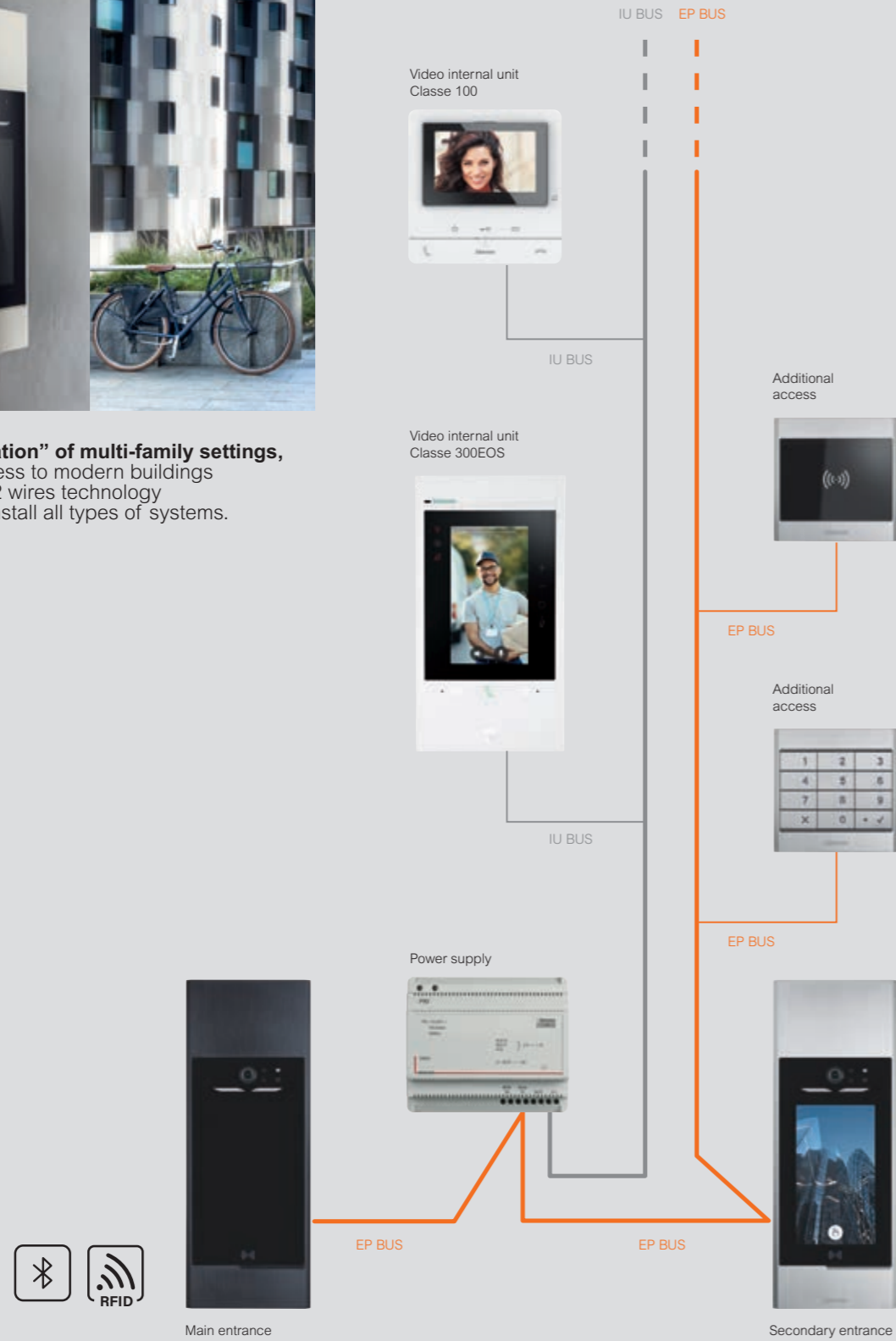

Also ideal for small installations and single-family or two family villas



Maximum versatility. Linea 5000 is the modern, simple and fast solution that is also perfectly suited for villas and detached and semi-detached single-family or two-family dwellings.

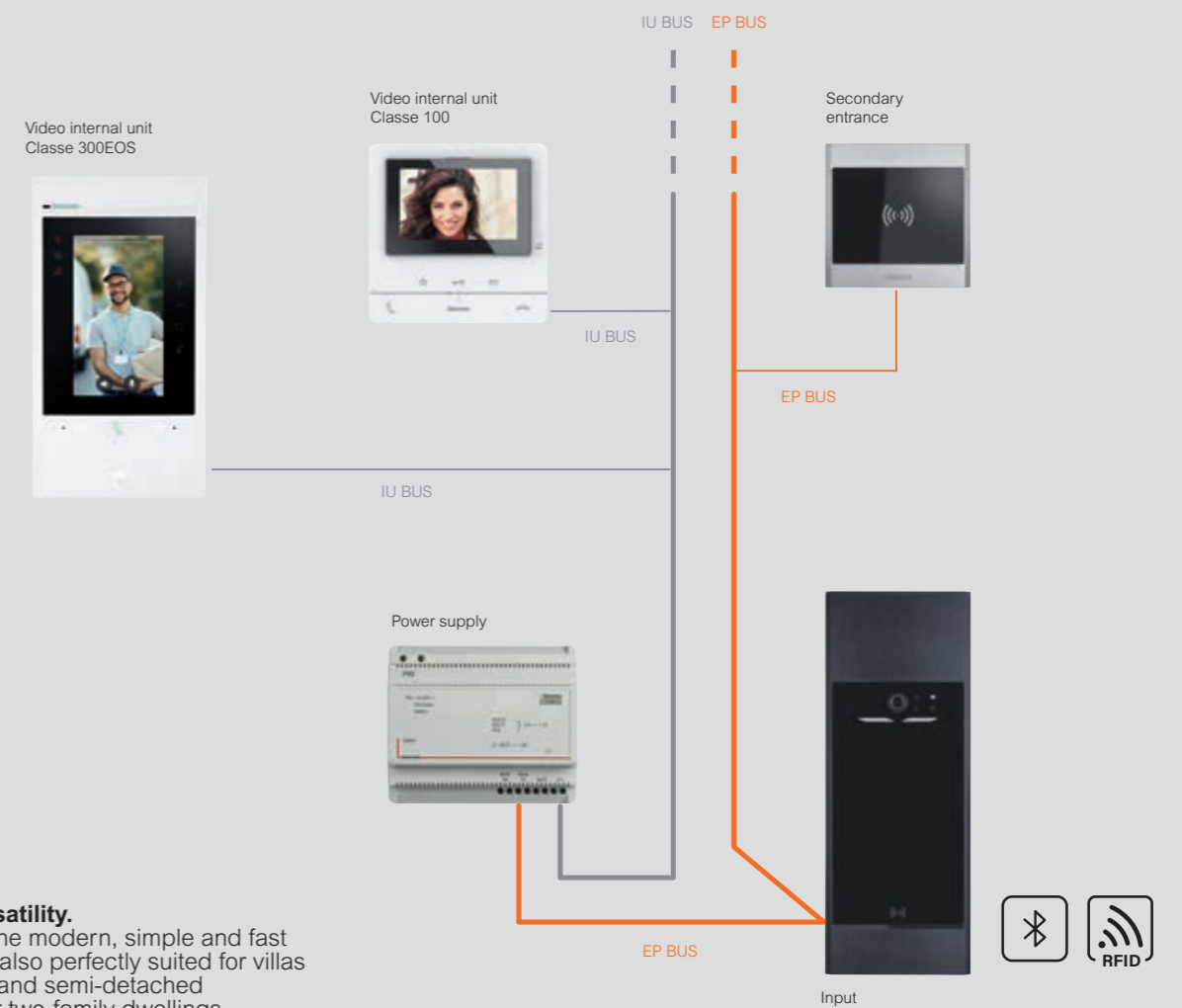

The Linea 5000 with Netatmo entrance panels and their add-on modules can be installed flush mounted or surface/wall mounted in different combinations, as shown in the following installation examples.

**Flush mounted installation of the display module**

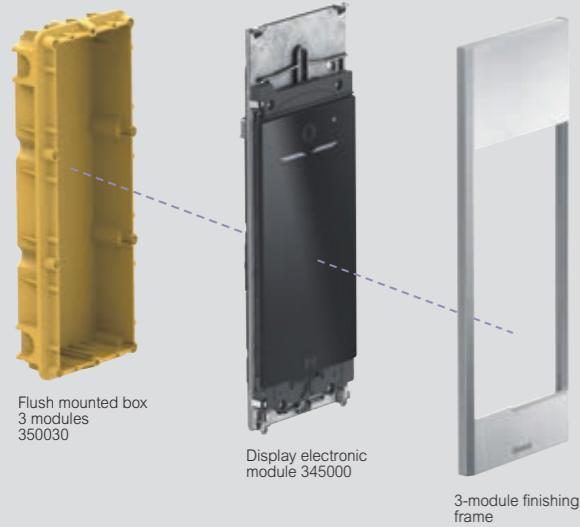

**3-module finishing frames**

**In the catalogue**

345101 Aluminium	345102 Nickel

**Made to order**

345103 Gold	345104 Titanium	345105 Steel

**Wall or surface mounted installation of the display module**



**3-module wall mounted boxes with rainshield**

345331 Aluminium	345332 Nickel

**Stand alone flush mounted installation of the additional modules**

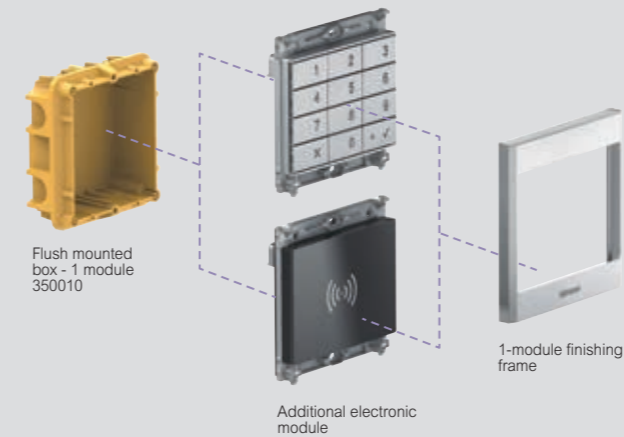

**1-module finishing frames**

345201 Aluminium	345202 Nickel	
345203 Gold	345204 Titanium	345205 Steel

**Additional modules**

**Keypad modules**

345500 Aluminium	345510 Nickel

**RFID Smart Access module**

345520

**Stand alone wall mounted installation of the additional modules**

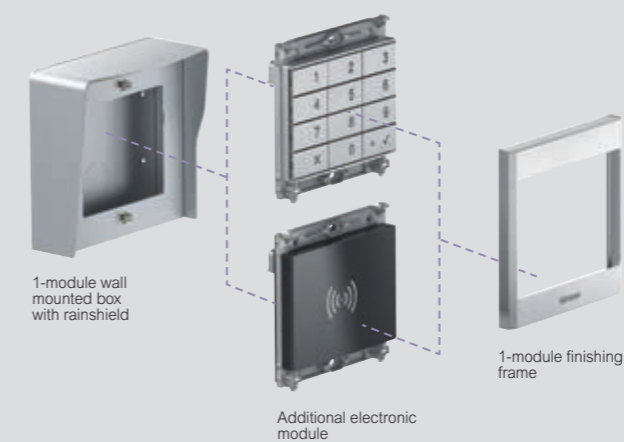

**1-module wall mounted boxes with rainshield**

345311 Aluminium	345312 Nickel

**Flush mounted installation (3 + 1)**  
of the display module + additional module

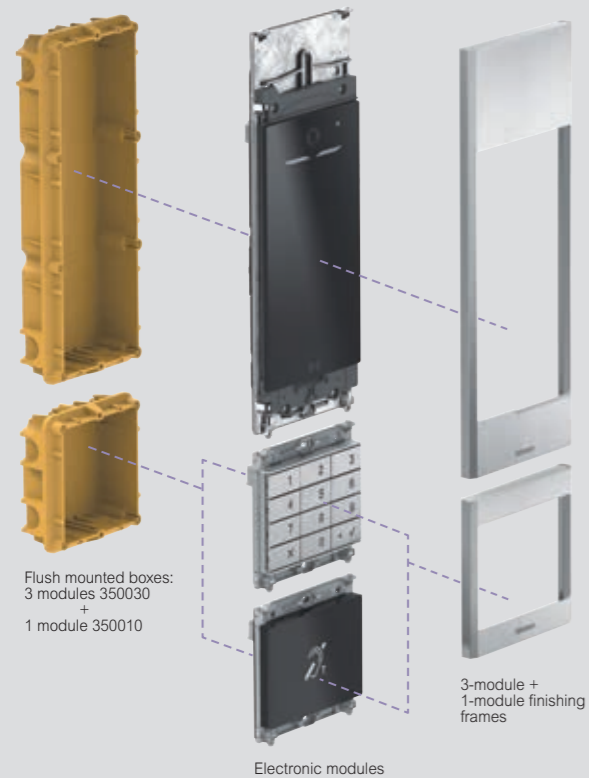

**Wall mounted installation (3 + 1)**  
of the display module + additional module

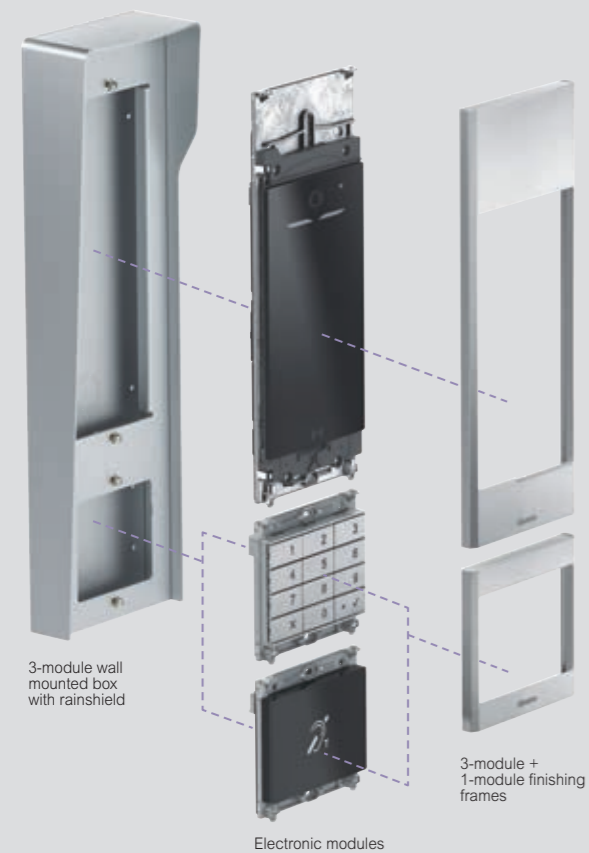

**3-module finishing frames**

**In the catalogue**



345101  
Aluminium

345102  
Nickel

**Made to order**

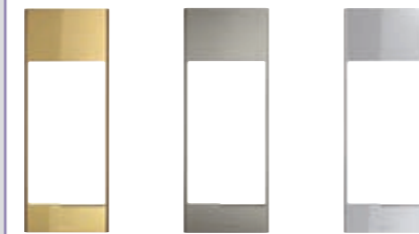

345103  
Gold

345104  
Titanium

345105  
Steel

**1-module finishing frames**

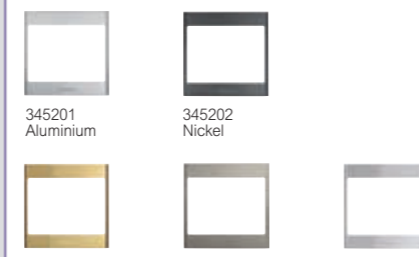

345201  
Aluminium

345202  
Nickel

345203  
Gold

345204  
Titanium

345205  
Steel

**Additional modules**

**Keypad modules**



345500  
Aluminium

345510  
Nickel

**Inductive loop module**



345530

**Wall mounted boxes with rainshield (3+ 1) modules**



345341  
Aluminium

345342  
Nickel



**Item 345000 Display module**

**7" vertical display module with wide-angle HD camera (5 M Pixels).**

Display and audio/video module to be combined with one of the 5 frames in different finishes for the creation of 2 wires systems. Equipped with an HD camera with wide-angle field of view (130° horizontal), white LEDs for lighting and twilight sensor for night vision. High-resolution 7" touch screen display with shatter-proof glass (IK08), anti-fingerprint and proximity sensor for automatic switching on. With a digital microphone and echo eliminator for optimal sound performance. The flexible and user-friendly graphic interface is adaptable to any type of apartment block and allows a choice of 3 different call modes: address book call (list of residents' names), numeric or alphanumeric code call and block-staircase-floor-apartment logic code call. The direct call to the guard station and the customisation of the homepage logos also make it suitable for solutions with concierge or for commercial establishments. With advanced features such as voice feedback, automatic theme change (light/dark), customisation of welcome messages or instructions and temporary access code forwarding, it is suitable for residents and visitors of all ages and abilities. It also supports different modes for accessing the building: lock release with display code, RFID badge or Bluetooth via the Home + Security App, the resident's app. Programming and configuration requires the use of Home + Project (App or PC), the digital tool for the professional. Using this tool, it is possible to complete the entire configuration at the office, share it with other professionals and upload it to the display module via Bluetooth. Changes to residents' names and access codes are quick and smart, either on-site (via Bluetooth) or remotely (if the module has an active WiFi or Ethernet connection). Installation with 3-module flush mounted box 350030 or with wall mounted box 345331 or 345332. The book-like opening of the module allows for easy wiring. It allows the activation of an electrical door lock directly connected to clamps S+ and S- (18 V 4 A impulsive - 250 mA holding current 30 Ohm max) and of connecting a local door lock release pushbutton on clamps PL.

**Item 345101 Finishing frames - in the catalogue**

**345101 3-module frame – Aluminum finish**  
3-module frame in aluminum finish for display module 345000

**345102 3-module frame – Nickel finish**  
As 345101 but with Nickel finish

**Item 345103 Finishing frames - made to order**

**345103 3-module frame – Gold finish**  
3-module frame in Gold finish for display module 345000

**345104 3-module frame – Titanium finish**  
As 345103 but with Titanium finish

**345105 3-module frame – Steel finish**  
As 345103 but with Steel finish

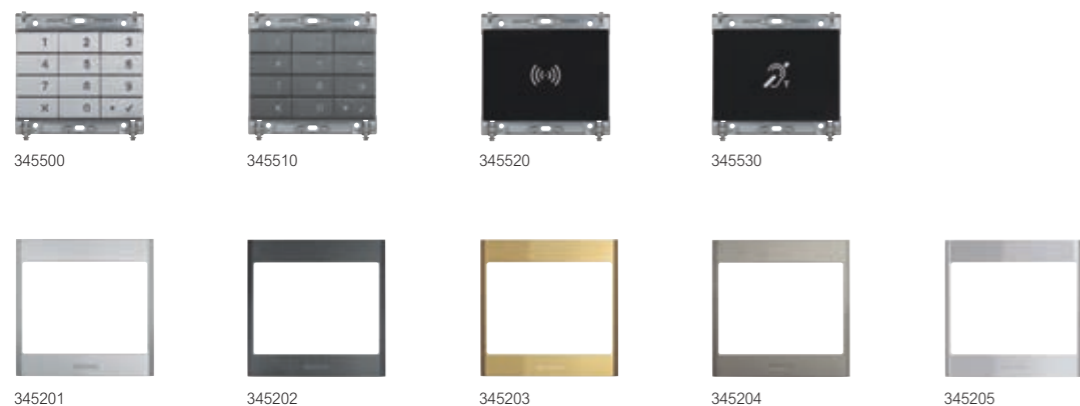

Item	Keypad modules
345500	<b>Additional keypad module in Aluminum finish</b> Keypad module with aluminium key finish for door lock opening in 2-wire systems where there is at least one Linea 5000 display module (345000). The keypad module is fitted with relay contacts (C - NO - NC) and clamps (CP - P1) for the connection of a local door release pushbutton and can be programmed using the Home + Project app. It has a programming reset pushbutton, LEDs for the visual notification of the access status and night backlighting. The device, to be completed with an appropriate frame, can be used stand-alone or combined with a display module in a 3+1 composition. To be installed in 1-module flush mounted box 350010, in wall mounted box 345311 or with dedicated accessory 345341 for 3+1 composition.
345510	<b>Additional keypad module in Nickel finish</b> As 345500 but with NICKEL finish
<b>1-module finishing frames</b>	
345201	<b>1-module frame – Aluminum finish</b> 1-module frame in aluminium finish for electronic modules 345500 - 345510 - 345520 - 345530.
345202	<b>1-module frame – Nickel finish</b> As 345201 but with Nickel finish
345203	<b>1-module frame – Gold finish</b> As 345201 but with Gold finish
345204	<b>1-module frame – Titanium finish</b> As 345201 but with Titanium finish
345205	<b>1-module frame – Steel finish</b> As 345201 but with Steel finish

Item	RFID Smart access module
345520	<b>Additional RFID Smart access module</b> RFID/bluetooth smart access module for door lock opening in 2-wire systems where there is at least one Linea 5000 display module (345000), using the badge or using the Home + Security App via bluetooth. The smart access module is fitted with relay contacts (C - NO - NC) and clamps (CP - P1) for the connection of a local door release pushbutton and can be programmed using the Home + Project app. It has a programming reset pushbutton, LEDs for the visual notification of the access status and night backlighting. The device, to be completed with an appropriate finishing frame, can be installed in 1-module flush mounted box 350010 or in wall mounted box 345311 or 345312.
<b>Inductive loop module</b>	
345530	<b>Additional Inductive loop module</b> Inductive loop module to be used in conjunction with the display module Linea 5000 (345000). It allows people wearing hearing aids fitted with (T) selector to use audio door entry communication. In this mode, the hearing aid receives the audio signal directly from the amplification system, bypassing the microphone of the hearing aid itself, improving audio quality and reducing background noise. It is connected to the display module using the appropriate multicable supplied. To be completed with the appropriate finishing frame (available in 5 finishes) The device CANNOT be used stand-alone but only as additional module in conjunction with the Linea 5000 display (345000). To be installed in 1-module flush mounted box 350010 or with the dedicated accessory 345341 or 345342 for 3+1 composition.

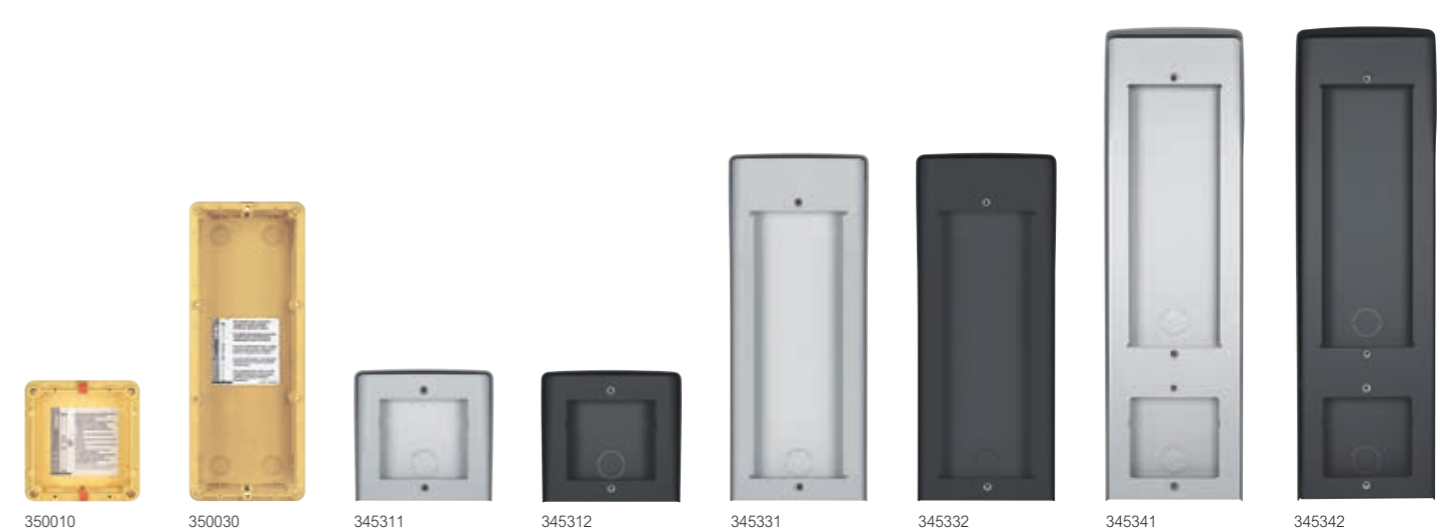

Item	XL accessory plates
345111	<b>XL cover plate– Aluminium finish</b> XL accessory plate in aluminium finish used for the installation of Linea 5000 entrance panels in place of existing multi-pushbutton panels. The XL dimensions allow for easy replacement by covering the hole left by the existing plate, optimised for three 3-module boxes side by side.
345112	<b>XL cover plate– Nickel finish</b> As 345111 but with Nickel finish
<b>Accessory plates compatible with LINEA 300</b>	
345121	<b>Accessory plate compatible with Linea 300 – Aluminium finish</b> Accessory plate in Aluminium finish compatible with the Linea 300 pushbutton panels. Used for the installation of Linea 5000 entrance panels in replacement of existing Linea 300 pushbutton panels. The specific dimensions allow easy installation of the Linea 5000 digital display module to replace an existing Linea 300 pushbutton panel.
345122	<b>Accessory plate compatible with Linea 300 – Nickel finish</b> As 345121 but with Nickel finish

Item	Flush mounted boxes
350010	<b>Flush mounted box - 1 module</b> Plastic flush mounted box – 1 module
350030	<b>Flush mounted box – 3 modules</b> Plastic flush mounted box – 3 modules
<b>Wall mounted box with rainshield</b>	
345311	<b>Wall mounted box – 1 module- Aluminium finish</b> Wall mounted box with integrated rainshield – 1 module – Aluminium finish.
345312	<b>Wall mounted box – 1 module - Nickel finish</b> As 345311 but with Nickel finish
345331	<b>Wall mounted box – 3 modules - Aluminium finish</b> Wall mounted box with integrated rainshield – 3 modules – Aluminium finish.
345332	<b>Wall mounted box – 3 modules - Nickel finish</b> As 345331 but with Nickel finish
345341	<b>Wall mounted box – 4 modules - Aluminium finish</b> Wall mounted box with integrated rainshield – (3+ 1 ) modules – Aluminium finish.
345342	<b>Wall mounted box – 4 modules - Nickel finish</b> As 345341 but with Nickel finish



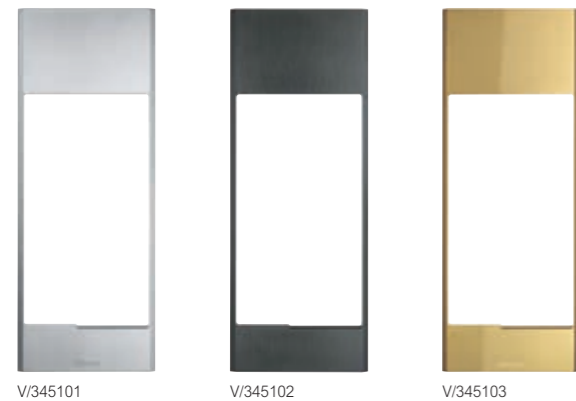

V/345101 V/345102 V/345103

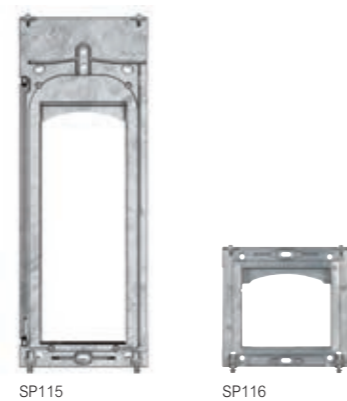

SP115 SP116



V/345104 V/345105

Item	Customisable 3-module finishing frames
V/345101	<b>Customisable 3-module frame - Aluminum finish</b> 3-module frame that can be customised with dedicated graphics and logos on request. Aluminium finish. Frame to complete the 345000 display module.
V/345102	<b>Customisable 3-module frame - Nickel finish</b> As V/345101 but with Nickel finish
V/345103	<b>Customisable 3-module frame - Gold finish</b> As V/345101 but with Gold finish
V/345104	<b>Customisable 3-module frame - Titanium finish</b> As V/345101 but with Titanium finish
V/345105	<b>Customisable 3-module frame - Steel finish</b> As V/345101 but with Steel finish

Item	3-module support frame
SP115	<b>3-module support frame</b> Spare part - 3-module aluminium support frame
SP116	<b>1-module support frame</b> Spare part - 1-module aluminium support frame

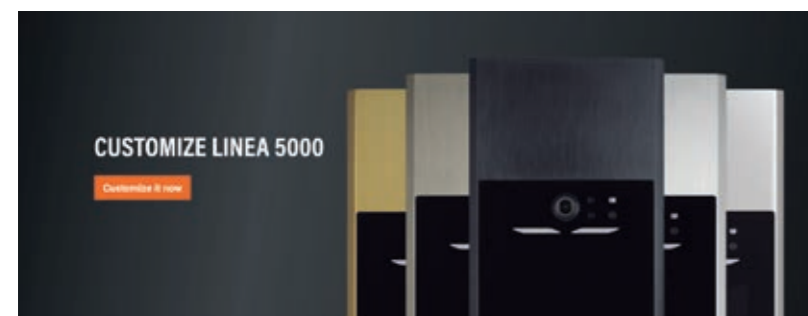

For the customisation of custom finishing frames with specific logos, text and graphics, use the online tool accessible through the **YouDiagram** software, the **video door entry system configurator** and the **www.bticino.com** portal.



Item	RFID programmable keycards
348200	Door lock release keycard - black
348201	Door lock release keycard - red
348202	Door lock release keycard - green
348203	Door lock release keycard - blue
348204	Door lock release keycard - orange
348205	Door lock release keycard - grey
348206	Door lock release keycard - yellow



■ Display module with camera

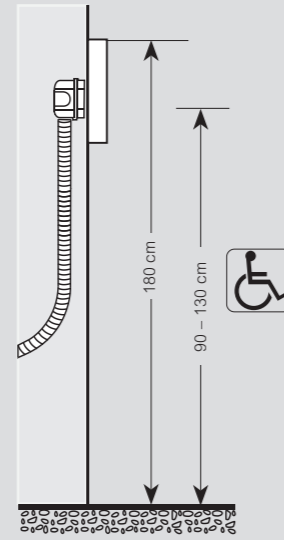
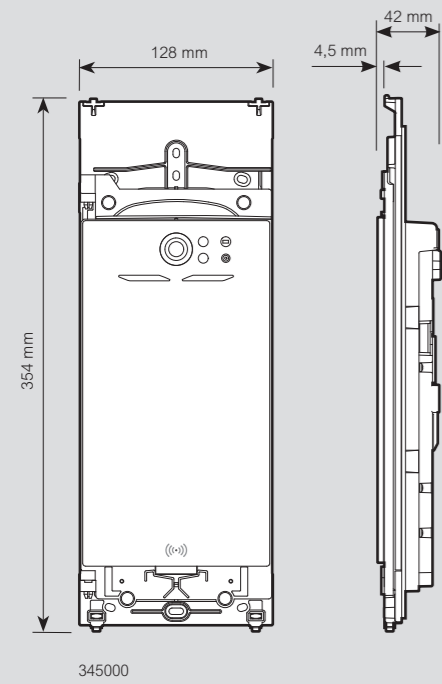

■ STANDARD 3-module finishing frames

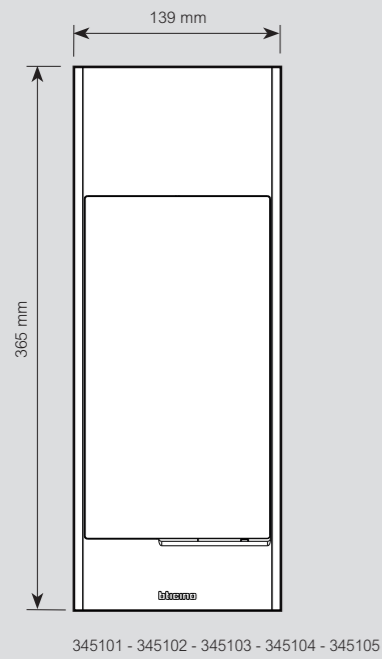

■ CUSTOMISABLE 3-module finishing frames

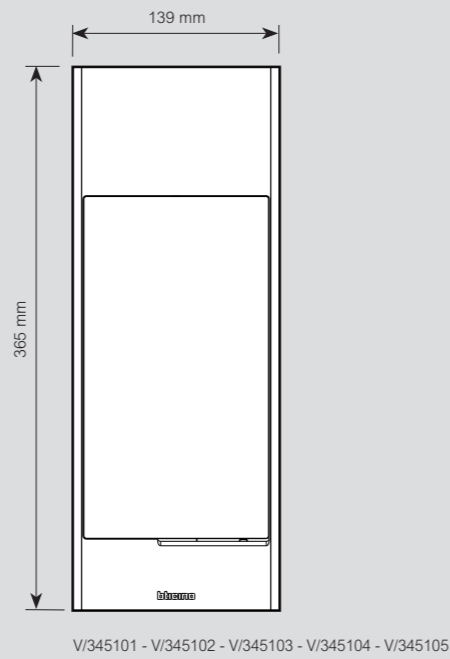

■ Additional keypad modules

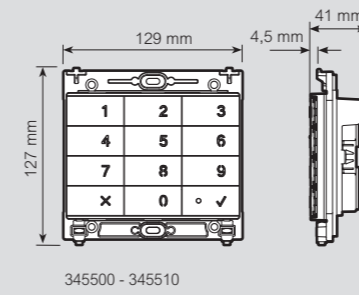

■ Additional RFID Smart Access module

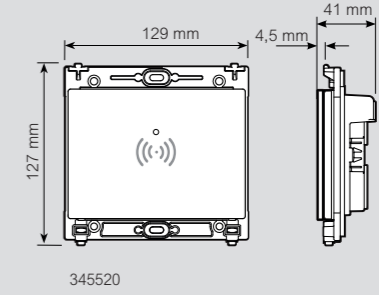

■ Additional Inductive loop module

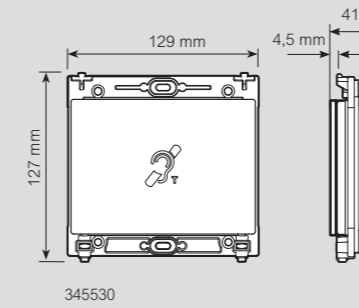

■ 1-module finishing frames

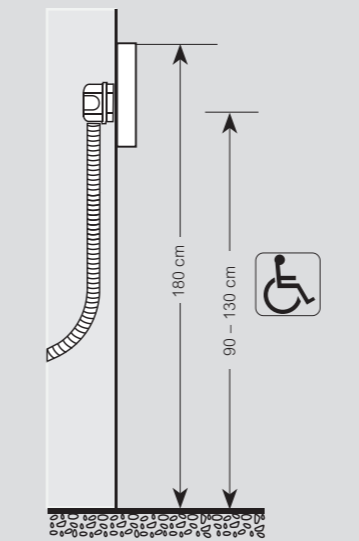
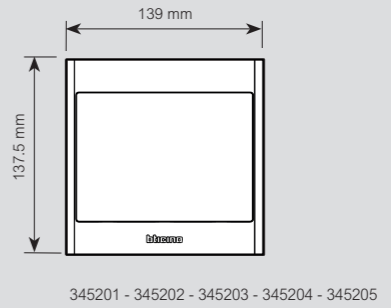

1 and 3-module flush mounted boxes

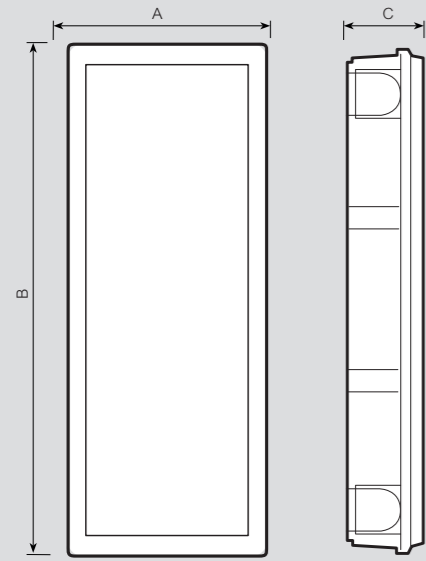

350010 - 350030

DIMENSIONS			
Item	A	B	C
350010	117	123	45
350030	117	306	45

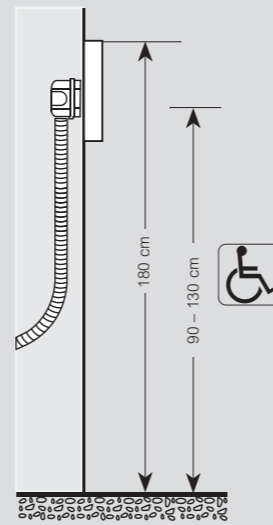

3-module wall mounted boxes

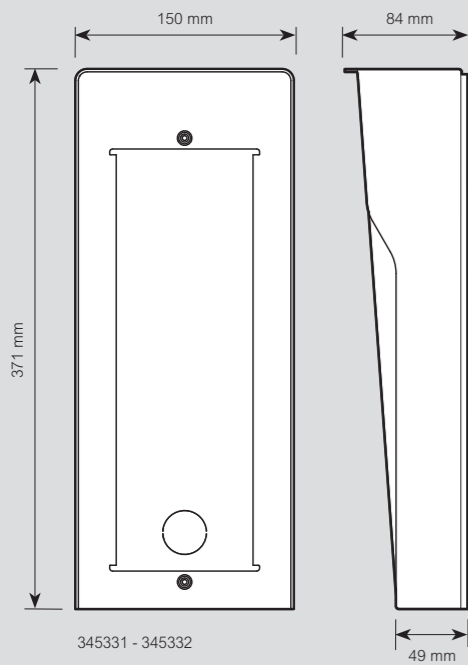

345331 - 345332

49 mm

Wall mounted boxes - 3 + 1 modules

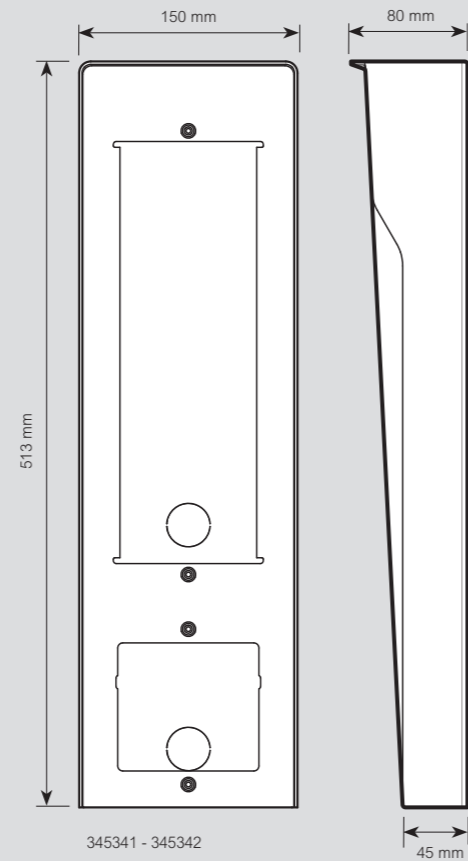

345341 - 345342

45 mm

1-module wall mounted boxes

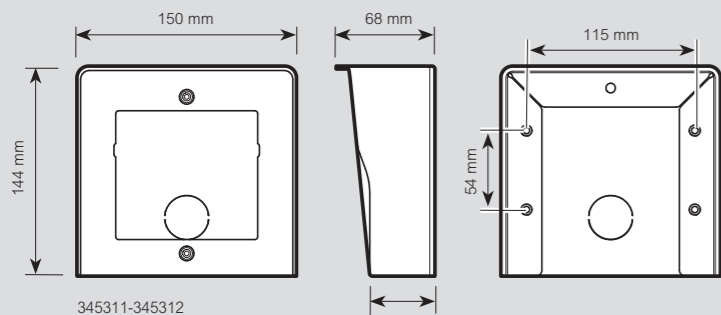

345311-345312

XL cover plates

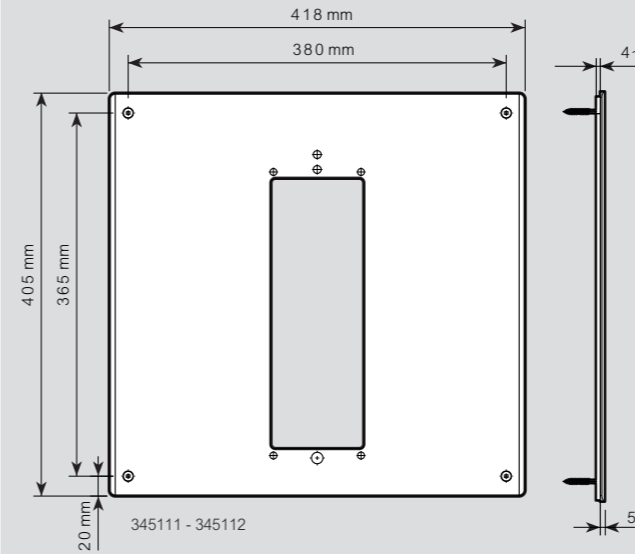

Cover plates compatible with Linea 300

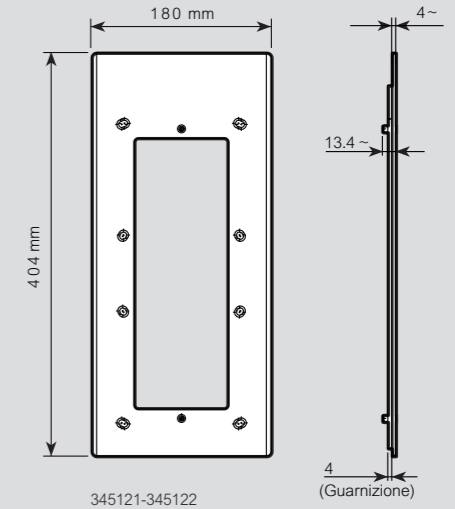

3-module support frame

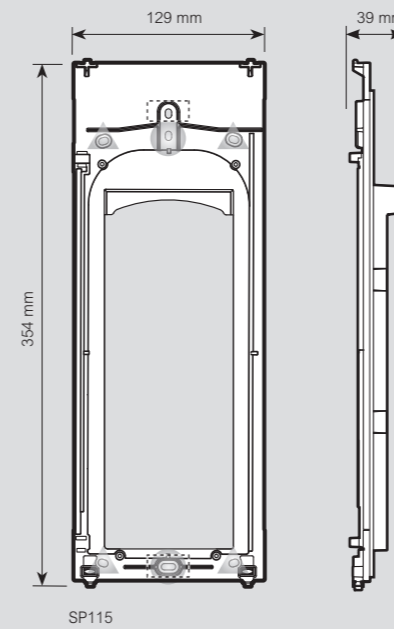

SP115

1-module support frame

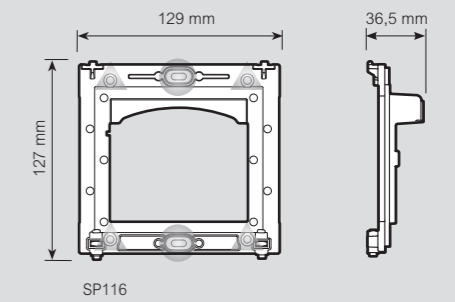

SP116

# Linea 5000 Digital. Functional. Performing.



## Online design, budgeting and customisation tools



### YouDiagram

**Software for the design and budgeting of BTicino audio and video door entry systems (2 wires, IP, 8 wires, analogue).**

It gives the possibility of creating a single line diagram of the system, which can then be exported in PDF and DXF format, of selecting the products and their finishes, of configuring the devices and checking current consumptions.

**Can be downloaded from:** <https://www.bticino.com/tools/design-software/youdiagram>



### Video door entry system Configurator

**Web app for the configuration and budgeting of audio and video door entry systems for villas and apartment blocks.**

What it allows to do:

1. **System creation**, depending on the type of system and the characteristics of the property.
2. **Get an estimate**. At the end of the configuration, a detailed and complete list of materials is generated.
3. **Access the project at any time**. Access the restricted area to view or modify the project.

**Accessible from:** <https://vdeconfigurator.bticino.com/>

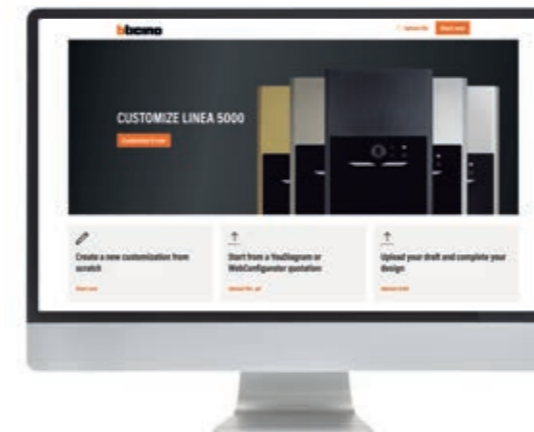

### Online tool for the customisation of the Linea 5000 finishing frames

**Online application for the customisation of Linea 5000 finishing frames with specific text, logos and graphics.**

After completing the online customisation process, the user can print a PDF file with a unique code.

The wholesaler receives the PDF file from the installer/commercial representative and sends it to BTicino together with the order. At BTicino, the order is processed as a "special order".

**Accessible from:** YouDiagram software

**BTicino** SpA  
Viale Borri, 231  
21100 Varese - Italy  
[www.bticino.com](http://www.bticino.com)

Elkesan Oy  
82200 Hammasmahti  
Finland  
+358 20 798 1060  
[www.elkesan.fi](http://www.elkesan.fi)  
[info@elkesan.fi](mailto:info@elkesan.fi)

**bticino**  
A brand of  **legrand**

AD-EXCML5000/24C/ENG - Version 06/2024

In accordance with its continuous improvement policy, the Company reserves the right to change specifications and designs without prior notice.  
All illustrations, descriptions, dimensions and information appearing in the catalogue are indicative and cannot be considered binding for the Company.